



CECIL[®]

Robotic Steam Generator Maintenance System

CECIL (Consolidated Edison Combined Inspection and Lancing) is a robotic steam generator maintenance system developed for secondary side maintenance. By accessing the entire in-bundle area of the tubesheet, CECIL can provide superior cleaning capabilities, reduces maintenance costs and personnel exposure to radiation and extends the life for pressurized water reactor (PWR) steam generators.

Problem:

Conventional sludge lancing (water spray) techniques do not remove all the corrosive sludge material that builds up on the tubesheet. Foreign object retrieval has been difficult in the annulus region and virtually impossible in the tube bundle. Corrosion products formed throughout the secondary cycle settle on top of the tubesheet and promote degradation of the tube bundle. Foreign objects introduced during initial fabrication or maintenance activities also impinge on tubes during operation and can eventually wear through tube walls causing primary to secondary leakage.

Forced outages to repair tube leaks are very costly, typically lasting 14 days and incurring costs of about \$6 million. When tubes are damaged and plugged, the steam generator must be replaced costing over \$300 million at some nuclear plants. In addition, exposure to high radiation is unsafe.

CECIL reduces these issues by its ability to access the tube bundle interior, remove sludge without damaging tubes, identify and remove foreign objects, and at the same time reduce personnel exposure to radiation.

Features/Benefits:

- Reduces maintenance cost
- Extends steam generator life
- Limits forced outages
- Increases personnel safety
- Increases productivity
- Reduces tube corrosion
- Improves inspection capabilities
- Decreases radiation exposure
- Removes sludge without damaging tubes
- Identifies and removes foreign objects
- Enhanced output and efficiency

Robotic Steam Generator Maintenance System

How CECIL Works:

The CECIL robot is remotely operated and can perform secondary side visual inspections, soft and hard sludge removal, sludge sampling, and both in-bundle and annulus foreign object search and retrieval (FOSAR). The key to CECIL's success is its ability to access the entire in-bundle area of the tubesheet.

The CECIL robot rides on a rail assembly installed through the open steam generator inspection port. The robot can move longitudinally along the rail assembly and extend and retract a flexible lance, which can be driven down the narrow (approximately 0.3 inches to as low as 0.115 inches) gaps between the columns of U-tubes.

The robot also can rotate about its axis to position the lance at any point within the tube bundle above the tubesheet and below the first support plate. The robot's flex lances are the transport mechanism for delivering spray nozzles and videoprobe deep into the tube bundle.

CECIL has three types of intertube lances:

1. HSL for removing hard sludge deposits from the tube lane (10 gpm at 6,000 lb/in.²)
2. SSL for removing soft sludge from the tube lanes and shadow zones between tube lanes (10 gpm at 2,500 lb/in.²)
3. DSL configured to remove hard sludge from the tubes and tubesheet (10 gpm at approx 6,000 lb/in.²)

CECIL is also equipped for conventional lancing with eight nozzles built into the robot body. These high volume, medium pressure barrel spray water jets (40 gpm at about 1500 lb/in.²) are directed down the blowdown lane to flush soft sludge and loosened debris from the tube bundle. Water for CECIL cleaning operations is recycled by a sludge processing/pumping system to reduce water waste.



Figure 1: CECIL's shadow zone lance effectively removes soft sludge from as tube lands and shadow zones between tube lanes

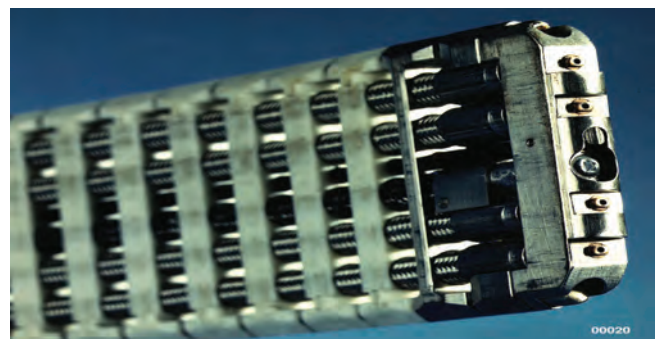

Figure 2: CECIL lance for removing hard sludge deposits

CECIL®

Robotic Steam Generator Maintenance System

CECIL activities are controlled from a remote control station (Figure 3) and monitored with video cameras, typically situated in a low radiation area on the operating level. Video monitors are located inside the steam generator and on the handhole platform. Real-time graphics show the robot and lance positions in the generator at all times and images are stored for future reference (Figure 4).



Figure 3: CECIL Control Station

CECIL-5 was developed to incorporate foreign object search and retrieval. Both FOSAR systems are compatible with existing CECIL system technology and both use an adaptation of the lance to deliver grapple tools inside the generator.

1. In-bundle FOSAR to locate and retrieve objects trapped inside the tube bundle. Offers four tools available to retrieve objects of varying shapes and sizes from the narrow gap between tubes.
2. Annulus FOSAR for object removal from the annulus region between the tube bundle and steam generator wall. Offers a larger, stronger two-prong end effector, capable of removing bigger, heavier objects.



Figure 4: CECIL Control Screen

CECIL technology is licensed for use in Japan by Mitsubishi Heavy Industries, France and other selected European countries by SRA/Electricite de France.

The CECIL robot is designed to inspect and clean Westinghouse Model 44, Model 51 steam generators, Mitsubishi models 44 and 51, Framatome 900MWe CPO and 1300MWe steam generators and CANDU steam generators. CECIL can also provide cleaning capability for the new Korean APR 1400 steam generators.

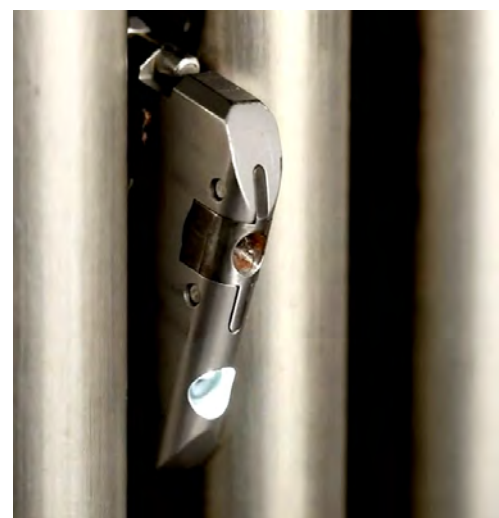

Figure 5: CECIL FOSAR

CECIL[®]

Robotic Steam Generator Maintenance System

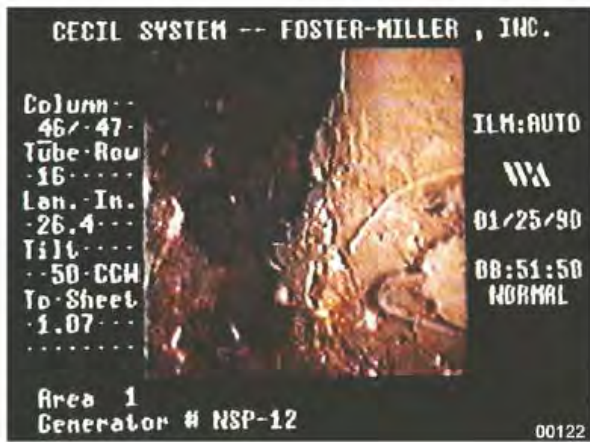

Figure 7: Typical in-bundle conditions after conventional lancing

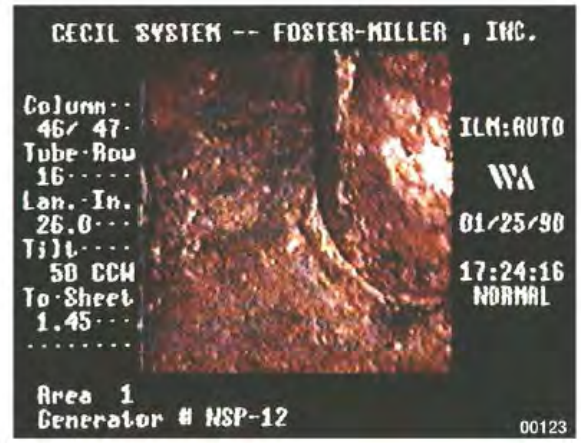

Figure 8: Same tube location after CECIL interlub lancing



Figure 9: CECIL 5

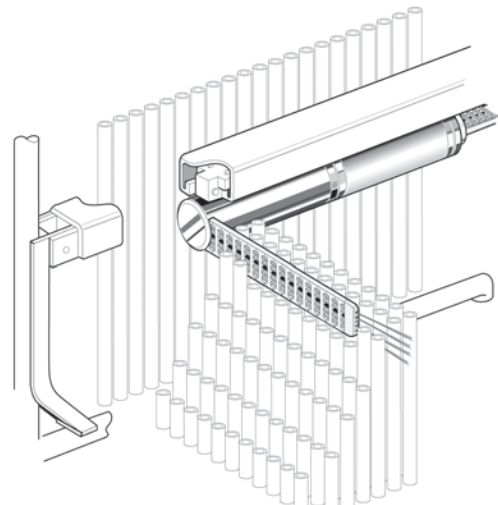

Figure 10: CECIL overview illustration

QinetiQ North America

350 Second Avenue

Waltham, MA 02451

1.781.684.4000

www.QinetiQ-NA.com

ContactUs@QinetiQ-NA.com